

# Oiles Drymet LF Polytetrafluoroethylene plastic multi-layer bearings with back metals

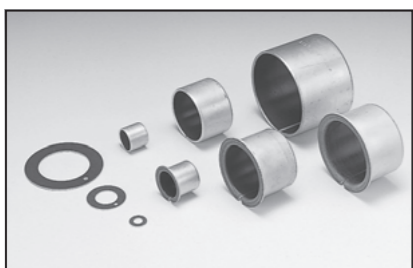

## Feature

- Serviceable without the need for lubrication. Thin and lightweight for compact design.
- Demonstrate low coefficient of friction and superior load performances in high-load, low-speed conditions.
- Usable at the high PV values even in the middle- and high-speed zones when lubricated.
- Usable in wide temperature ranges from low to high temperatures. Has superior chemical resistance.
- Features superior dimensional stability, mechanical strength, and thermal conductivity.
- The standard products and plate materials are available in various sizes.

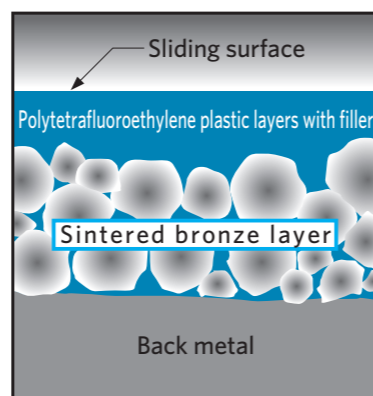

image

## Service range

Lubrication condition	Dry
Service temperature range °C	-200~+280
Allowable max. pressure <b>P</b> N/mm <sup>2</sup> {kgf/cm <sup>2</sup> }	49.0 (137) {500 (1,400)}
Allowable max. velocity <b>V</b> m/s {m/min}	0.65 {39}
Allowable max. <b>PV</b> value N/mm <sup>2</sup> · m/s {kgf/cm <sup>2</sup> · m/min}	3.60 {2,200}

The values in parentheses are static bearing pressures, which are the bearing pressures in applications with no motion or very small motion ( $\leq 0.0017$  m/s {0.1 m/min}).

※ Allowable max. pressure of LFCF is 24.5 N/mm<sup>2</sup> {250 Kgf/cm<sup>2</sup>}.

## Mechanical properties

Tensile strength	JIS Z 2241	N/mm <sup>2</sup> {kgf/cm <sup>2</sup> }	380 {3,875}
Elongation	JIS Z 2241	%	27
Hardness	JIS Z 2244	HV	107

※ The values shown above are typical values, not the standard values.

※ The values shown above are values of back metal.

## Test data

### Journal rotation test

<Testing conditions>

Bearing dimension :  $\phi 40 \times \phi 44 \times l 30$

Mating material : S45C

Pressure : 14.7, 8.8, N/mm<sup>2</sup>  
{150.0, 90.0 kgf/cm<sup>2</sup>}

Velocity : 0.088, 0.167 m/s  
{5.3, 10.0 m/min}

Test time : 100 hrs.

Lubrication : dry

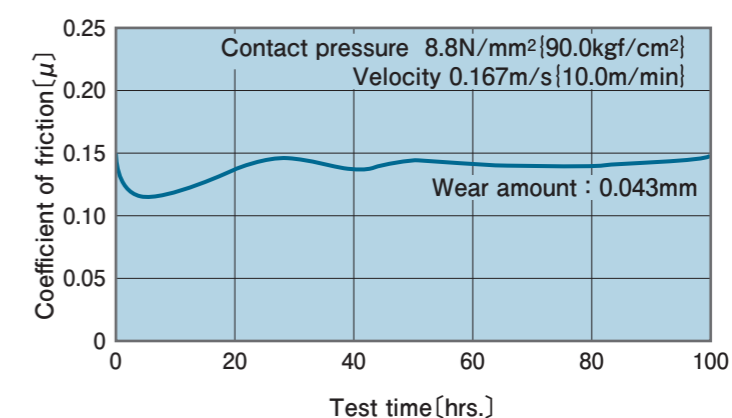
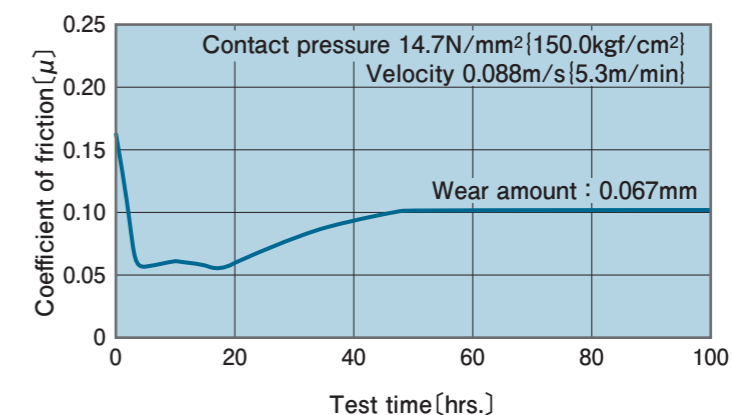
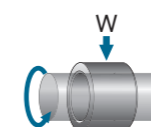

## Press-fitting (Rolled bushing)

### Press-fitting jig

Generally, as shown in the figure 1, a mandrel is used for the press-fitting. However use of a guide ring facilitates easier press-fitting. Use of a guide ring prevents damage of a bushing at the time of press-fitting. The dimension of a guide ring should be calculated from the table below.

Inner diameter of the guide ring should be the size so that the bushing can be inserted by hands. Length of the guide ring should be more than one-third of the bushing, or if possible, it should be the same length as the bushing.

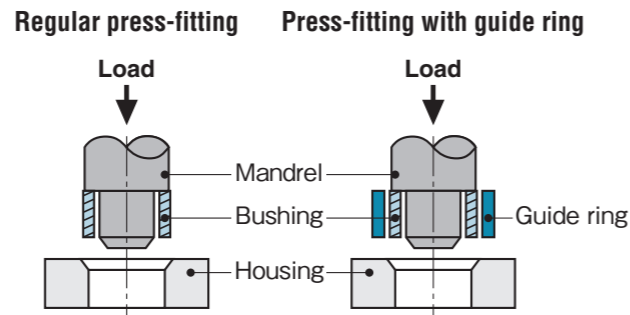

Figure 1

The dimension of mandrel should be calculated from table below.

Dimension of bushing		Dimension of mandrel
I.D.	D <sub>0</sub>	*1 d <sub>0</sub> = D <sub>0</sub> - (0.05 to 0.10)
O.D.	D <sub>1</sub>	*2 d <sub>1</sub> = D <sub>1</sub> - (0.20 to 0.30)
Length	L	ℓ ≥ L

\*1 Techmet B Standard Type (TCB) should be D<sub>0</sub> - (0.25 to 0.30).

\*2 Use of flange bushings should be the same size of flange.

The dimension of guide ring should be calculated from table below.

Dimension of bushing	Guide ring I.D.	Guide ring O.D.
Up to φ40	D <sub>1</sub> + (0.1 to 0.3)	
φ42 to φ60	D <sub>1</sub> + (0.2 to 0.5)	D <sub>1</sub> + (10 to 15)
Over φ65	D <sub>1</sub> + (0.5 to 1.0)	

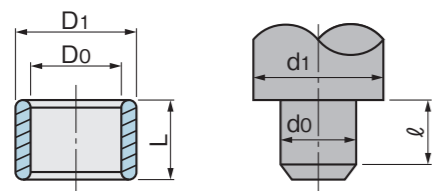

Figure 2

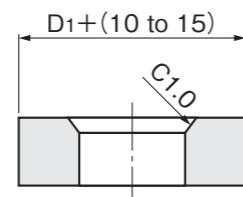

Figure 3

Inner diameter of the guide ring should be the size that bushing can be inserted by hands. The length of the guide ring should be more than one-third of the bushing, or if possible, it should be the same length as the bushing.

### Housing chamfer

For the housing chamfer, either a round chamfer or a tapered chamfer is recommended. In case of a C-surface chamfer, (more than C1.0) make sure there is no burr. Smoother press-fitting is possible by applying small amount of grease or lubricant.

### Press-fit force

Press-fit smoothly with hydraulic (pressure), pneumatic pressure, or a vice.

Avoid press-fit by use of impact such as use of a hammer.

It might induce damage of the bushing, or change the size of the inner diameter after press-fit.

Press-fit force is obtained by below formula.

$$F = (0.9 \text{ to } 1.2) \times 10^4 \cdot \frac{t \cdot L \cdot S}{D_1} \text{ [kg]}$$

t : thickness of the steel backing  
L : length of the bushing  
S : average interference  
D<sub>1</sub> : O.D. of bushing

● Thickness of the steel backing

Drymet LF		Unit : mm
I.D. of bushing	t	
Up to φ18	0.65	
φ19 to φ25	1.15	
φ26 to φ40	1.65	
φ42 and over	2.15	
LFCF	0.25	

Techmet B		Unit : mm
I.D. of bushing	t	
Up to φ18	0.50	
φ20 to φ22	0.95	

Toughmet / Toughmet D		Unit : mm
I.D. of bushing	t	
Up to φ18	0.70	
φ19 to φ25	1.10	
φ26 to φ40	1.60	
φ42 and over	2.10	

\*LFCF is obtained by below formula.

$$F = (0.4 \text{ to } 0.8) \times 10^4 \cdot \frac{t \cdot L \cdot S}{D_1} \text{ [kg]}$$

Techmet E		Unit : mm
thickness of bearing	t	
0.5	0.25	
1.0	0.65	

\*Techmet E (t0.5) is obtained by below formula.

$$F = (0.4 \text{ to } 0.8) \times 10^4 \cdot \frac{t \cdot L \cdot S}{D_1} \text{ [kg]}$$

## Dimensional inspection and chamfering on Oiles Drymet LF

Oiles Drymet LF is dimensionally inspected before shipping as indicated below:

- The O.D. is checked by "GO" and "NO GO" ring gauges.
- The I.D. mounted in the "GO" ring gauge is checked by plug gauges.
- The "GO" ring gauge stands for the upper limit and the "NO GO" ring gauge the lower limit of the O.D. tolerance.
- Chamfering: Both ends of the I.D. and O.D. are chamfered as shown in the right diagram except those with the ID of 9mm or less which are not chamfered.

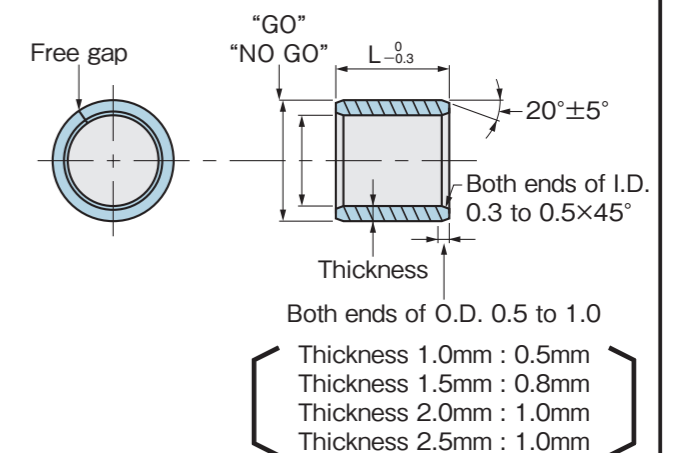

# LFB Oiles Drymet LF Bushings (I.D. $\phi 3 \sim \phi 28$ )

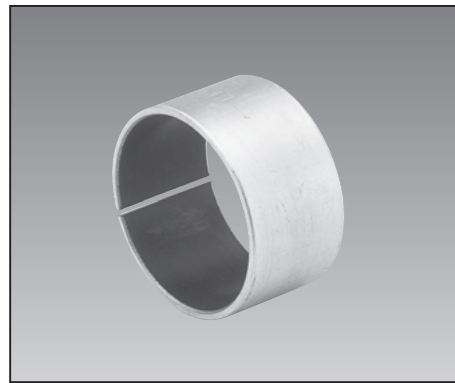

Specify Part No. by required I.D. and length.  
(e.g.) I.D. is 15mm and length is 8mm.

**LFB - 1508**  
Part No.

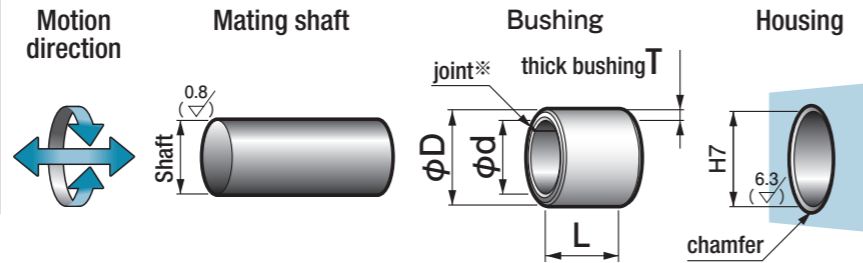

※The joint causes no influences upon rotation of the shaft. Be careful when press-fitting so that the joint is not at the position to which the maximum load is applied.

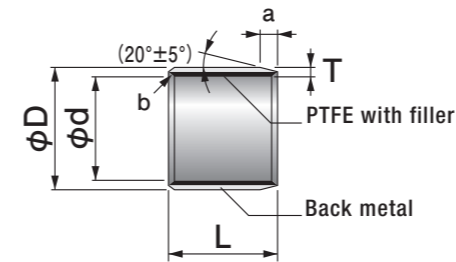

a: O.D. chamfering for the bushing I.D. of  $\phi 10$  or more

T	1.0	1.5	2.0
a	0.5	0.8	1.0

(mm)

b: I.D. chamfering for the bushing I.D. of  $\phi 10$  or more

T	1.0	1.5	2.0
b	C0.3	C0.5	C0.5

(mm)

※Chamfering of inner or outer diameters less than  $\phi 10$  mm is done only to remove burrs.

Shaft Size	Shaft Tolerance	Housing Size	Housing H7 Tolerance	I.D.		O.D.		Wall thickness		Length L Tolerance $_{-0.3}^0$					
				$\phi d$	$\phi D$	T	Tolerance	3	4	5	6	7	8		
3	$_{-0.025}^{-0.034}$	5	$_{0}^{+0.012}$	3	5	$_{0}^{+0.047}$	$_{-0.017}^{+0.017}$	1.0	$_{0}^{-0.025}$	0303	0304	0305	0306		
4	$_{-0.025}^{-0.037}$	6	$_{0}^{+0.012}$	4	6	$_{0}^{+0.047}$	$_{-0.017}^{+0.017}$	1.0	$_{0}^{-0.025}$	0403	0404	0405	0406		0408
5	$_{-0.025}^{-0.037}$	7	$_{0}^{+0.015}$	5	7	$_{0}^{+0.055}$	$_{-0.025}^{+0.025}$	1.0	$_{0}^{-0.025}$	0503	0504	0505	0506		0508
6	$_{-0.025}^{-0.037}$	8	$_{0}^{+0.015}$	6	8	$_{0}^{+0.055}$	$_{-0.025}^{+0.025}$	1.0	$_{0}^{-0.025}$	0603	0604	0605	0606	0607	0608
7	$_{-0.025}^{-0.040}$	9	$_{0}^{+0.015}$	7	9	$_{0}^{+0.055}$	$_{-0.025}^{+0.025}$	1.0	$_{0}^{-0.025}$			0705	0706	0707	0708
8	$_{-0.025}^{-0.040}$	10	$_{0}^{+0.015}$	8	10	$_{0}^{+0.055}$	$_{-0.025}^{+0.025}$	1.0	$_{0}^{-0.025}$			0805	0806	0807	0808
9	$_{-0.025}^{-0.040}$	11	$_{0}^{+0.018}$	9	11	$_{0}^{+0.060}$	$_{-0.030}^{+0.030}$	1.0	$_{0}^{-0.025}$				0906		
10	$_{-0.025}^{-0.040}$	12	$_{0}^{+0.018}$	10	12	$_{0}^{+0.060}$	$_{-0.030}^{+0.030}$	1.0	$_{0}^{-0.025}$				1006	1007	1008
12	$_{-0.025}^{-0.043}$	14	$_{0}^{+0.018}$	12	14	$_{0}^{+0.060}$	$_{-0.030}^{+0.030}$	1.0	$_{0}^{-0.025}$				1206		1208
13	$_{-0.025}^{-0.043}$	15	$_{0}^{+0.018}$	13	15	$_{0}^{+0.060}$	$_{-0.030}^{+0.030}$	1.0	$_{0}^{-0.025}$						1308
14	$_{-0.025}^{-0.043}$	16	$_{0}^{+0.018}$	14	16	$_{0}^{+0.065}$	$_{-0.035}^{+0.035}$	1.0	$_{0}^{-0.025}$						1408
15	$_{-0.025}^{-0.043}$	17	$_{0}^{+0.018}$	15	17	$_{0}^{+0.065}$	$_{-0.035}^{+0.035}$	1.0	$_{0}^{-0.025}$						1508
16	$_{-0.025}^{-0.043}$	18	$_{0}^{+0.018}$	16	18	$_{0}^{+0.070}$	$_{-0.035}^{+0.035}$	1.0	$_{0}^{-0.025}$						
17	$_{-0.025}^{-0.043}$	19	$_{0}^{+0.021}$	17	19	$_{0}^{+0.070}$	$_{-0.035}^{+0.035}$	1.0	$_{0}^{-0.025}$						
18	$_{-0.025}^{-0.043}$	20	$_{0}^{+0.021}$	18	20	$_{0}^{+0.075}$	$_{-0.040}^{+0.040}$	1.0	$_{0}^{-0.025}$						
19	$_{-0.025}^{-0.046}$	22	$_{0}^{+0.021}$	19	22	$_{0}^{+0.075}$	$_{-0.040}^{+0.040}$	1.5	$_{0}^{-0.030}$						
20	$_{-0.025}^{-0.046}$	23	$_{0}^{+0.021}$	20	23	$_{0}^{+0.080}$	$_{-0.045}^{+0.045}$	1.5	$_{0}^{-0.030}$						
22	$_{-0.025}^{-0.046}$	25	$_{0}^{+0.021}$	22	25	$_{0}^{+0.080}$	$_{-0.045}^{+0.045}$	1.5	$_{0}^{-0.030}$						
24	$_{-0.025}^{-0.046}$	27	$_{0}^{+0.021}$	24	27	$_{0}^{+0.080}$	$_{-0.045}^{+0.045}$	1.5	$_{0}^{-0.030}$						
25	$_{-0.025}^{-0.046}$	28	$_{0}^{+0.021}$	25	28	$_{0}^{+0.085}$	$_{-0.050}^{+0.050}$	1.5	$_{0}^{-0.030}$						
26	$_{-0.025}^{-0.046}$	30	$_{0}^{+0.021}$	26	30	$_{0}^{+0.085}$	$_{-0.050}^{+0.050}$	2.0	$_{0}^{-0.030}$						
28	$_{-0.025}^{-0.046}$	32	$_{0}^{+0.025}$	28	32	$_{0}^{+0.090}$	$_{-0.050}^{+0.050}$	2.0	$_{0}^{-0.030}$						

※Outer diameter is measured by exclusive gauge.  
 ※The I.D. tolerance after press fitting is for reference only.  
 ※I.D.  $\phi 30 \sim \phi 160$  are shown on pages 157 to 158.

Length L Tolerance $_{-0.3}^0$									I.D. tolerance after press fitting (reference)	I.D. $\phi d$
10	12	14	15	16	20	25	30	35		
									$_{0}^{+0.062}$	3
									$_{0}^{+0.062}$	4
									$_{0}^{+0.065}$	5
0610	0612								$_{0}^{+0.065}$	6
0710	0712								$_{0}^{+0.065}$	7
0810	0812		0815						$_{0}^{+0.065}$	8
0910									$_{0}^{+0.068}$	9
1010	1012		1015		1020				$_{0}^{+0.068}$	10
1210	1212		1215		1220				$_{0}^{+0.068}$	12
1310	1312		1315		1320				$_{0}^{+0.068}$	13
1410	1412	1414	1415	1416	1420				$_{0}^{+0.068}$	14
1510	1512		1515		1520	1525			$_{0}^{+0.068}$	15
1610	1612		1615		1620	1625			$_{0}^{+0.068}$	16
1710			1715						$_{0}^{+0.071}$	17
1810	1812		1815		1820	1825	1830		$_{0}^{+0.071}$	18
1910			1915		1920				$_{0}^{+0.081}$	19
2010	2012		2015		2020	2025	2030		$_{0}^{+0.081}$	20
2210	2212		2215		2220	2225	2230		$_{0}^{+0.081}$	22
			2415		2420	2425	2430		$_{0}^{+0.081}$	24
2510	2512		2515		2520	2525	2530	2535	$_{0}^{+0.081}$	25
			2615		2620	2625	2630		$_{0}^{+0.081}$	26
	2812		2815		2820	2825	2830		$_{0}^{+0.085}$	28

# LFB Oiles Drymet LF Bushings (I.D. $\phi 30 \sim \phi 160$ )



Specify Part No. by required I.D. and length.  
(e.g.) I.D. is 70mm and length is 35mm.

**LFB - 7035**  
Part No.

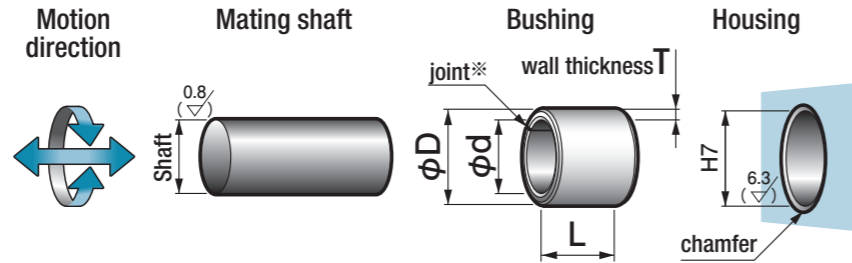

※The joint causes no influences upon rotation of the shaft. Be careful when press-fitting so that the joint is not at the position to which the maximum load is applied.

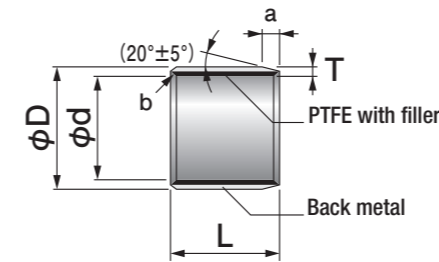

**a: O.D. chamfering**

T	2.0	2.5
a	1.0	1.0

(mm)

**b: I.D. chamfering**

T	2.0	2.5
b	C0.5	C0.5

(mm)

Shaft Size	Shaft Tolerance	Housing H7		I.D.		O.D.		Wall thickness T		Length L Tolerance $-0.3$					
		H7	Tolerance	$\phi d$	$\phi D$	T	Tolerance	12	15	20	25	30	35		
30	$-0.025$ $-0.046$	34	$+0.025$ 0	30	34	$+0.090$ $+0.050$	2.0	$0$ $-0.030$	<b>3012</b>	<b>3015</b>	<b>3020</b>	<b>3025</b>	<b>3030</b>	<b>3035</b>	
31	$-0.025$ $-0.050$	35	$+0.025$ 0	31	35	$+0.090$ $+0.050$	2.0	$0$ $-0.030$		<b>3115</b>		<b>3125</b>	<b>3130</b>		
32	$-0.025$ $-0.050$	36	$+0.025$ 0	32	36	$+0.090$ $+0.050$	2.0	$0$ $-0.030$		<b>3215</b>	<b>3220</b>	<b>3225</b>	<b>3230</b>		
35	$-0.025$ $-0.050$	39	$+0.025$ 0	35	39	$+0.095$ $+0.055$	2.0	$0$ $-0.030$	<b>3512</b>	<b>3515</b>	<b>3520</b>	<b>3525</b>	<b>3530</b>	<b>3535</b>	
38	$-0.025$ $-0.050$	42	$+0.025$ 0	38	42	$+0.095$ $+0.055$	2.0	$0$ $-0.030$			<b>3820</b>	<b>3825</b>	<b>3830</b>	<b>3835</b>	
40	$-0.025$ $-0.050$	44	$+0.025$ 0	40	44	$+0.095$ $+0.055$	2.0	$0$ $-0.030$	<b>4012</b>	<b>4015</b>	<b>4020</b>	<b>4025</b>	<b>4030</b>	<b>4035</b>	
45	$-0.025$ $-0.050$	50	$+0.025$ 0	45	50	$+0.100$ $+0.060$	2.5	$0$ $-0.040$			<b>4520</b>	<b>4525</b>	<b>4530</b>	<b>4535</b>	
50	$-0.025$ $-0.050$	55	$+0.030$ 0	50	55	$+0.105$ $+0.060$	2.5	$0$ $-0.040$			<b>5020</b>	<b>5025</b>	<b>5030</b>	<b>5035</b>	
55	$-0.025$ $-0.055$	60	$+0.030$ 0	55	60	$+0.110$ $+0.065$	2.5	$0$ $-0.040$				<b>5525</b>	<b>5530</b>	<b>5535</b>	
60	$-0.025$ $-0.055$	65	$+0.030$ 0	60	65	$+0.120$ $+0.070$	2.5	$0$ $-0.040$					<b>6030</b>	<b>6035</b>	
65	$+0.035$ $+0.005$	70	$+0.030$ 0	65	70	$+0.125$ $+0.075$	2.5	$-0.030$ $-0.080$					<b>6530</b>		
70	$+0.035$ $+0.005$	75	$+0.030$ 0	70	75	$+0.125$ $+0.075$	2.5	$-0.030$ $-0.080$					<b>7030</b>	<b>7035</b>	
75	$+0.035$ $+0.005$	80	$+0.030$ 0	75	80	$+0.130$ $+0.075$	2.5	$-0.030$ $-0.080$					<b>7530</b>	<b>7535</b>	
80	$+0.035$ $+0.005$	85	$+0.035$ 0	80	85	$+0.130$ $+0.075$	2.5	$-0.030$ $-0.080$							
85	$+0.035$ 0	90	$+0.035$ 0	85	90	$+0.130$ $+0.075$	2.5	$-0.030$ $-0.080$							
90	$+0.035$ 0	95	$+0.035$ 0	90	95	$+0.130$ $+0.075$	2.5	$-0.030$ $-0.080$							
100	$+0.035$ 0	105	$+0.035$ 0	100	105	$+0.140$ $+0.080$	2.5	$-0.030$ $-0.080$							
110	$+0.035$ 0	115	$+0.035$ 0	110	115	$+0.140$ $+0.080$	2.5	$-0.030$ $-0.080$							
120	$+0.035$ 0	125	$+0.040$ 0	120	125	$+0.145$ $+0.090$	2.5	$-0.030$ $-0.080$							
130	$+0.035$ $-0.005$	135	$+0.040$ 0	130	135	$+0.145$ $+0.090$	2.5	$-0.030$ $-0.080$							
140	$+0.035$ $-0.005$	145	$+0.040$ 0	140	145	$+0.165$ $+0.100$	2.5	$-0.030$ $-0.080$							
150	$+0.035$ $-0.005$	155	$+0.040$ 0	150	155	$+0.185$ $+0.120$	2.5	$-0.030$ $-0.080$							
160	$+0.035$ $-0.005$	165	$+0.040$ 0	160	165	$+0.185$ $+0.120$	2.5	$-0.030$ $-0.080$							

※Outer diameter is measured by exclusive gauge.  
※The I.D. tolerance after press fitting is for reference only.  
※I.D.  $\phi 3 \sim \phi 28$  are shown on pages 155 to 156.

Length L Tolerance $-0.3$								I.D. tolerance after press fitting (reference)	I.D. $\phi d$
40	50	60	70	80	90	95	100		
<b>3040</b>	<b>3050</b>							$+0.085$ 0	30
<b>3140</b>								$+0.085$ 0	31
<b>3240</b>								$+0.085$ 0	32
<b>3540</b>	<b>3550</b>							$+0.085$ 0	35
<b>3840</b>								$+0.085$ 0	38
<b>4040</b>	<b>4050</b>							$+0.085$ 0	40
<b>4540</b>	<b>4550</b>							$+0.105$ 0	45
<b>5040</b>	<b>5050</b>	<b>5060</b>						$+0.110$ 0	50
<b>5540</b>	<b>5550</b>	<b>5560</b>						$+0.110$ 0	55
<b>6040</b>	<b>6050</b>	<b>6060</b>						$+0.110$ 0	60
<b>6540</b>	<b>6550</b>	<b>6560</b>			<b>6080</b>			$+0.190$ $+0.060$	65
<b>7040</b>	<b>7050</b>	<b>7060</b>	<b>7070</b>	<b>7080</b>				$+0.190$ $+0.060$	70
<b>7540</b>	<b>7550</b>	<b>7560</b>		<b>7580</b>				$+0.190$ $+0.060$	75
<b>8040</b>	<b>8050</b>	<b>8060</b>		<b>8080</b>				$+0.195$ $+0.060$	80
<b>8540</b>	<b>8550</b>	<b>8560</b>		<b>8580</b>				$+0.195$ $+0.060$	85
<b>9040</b>	<b>9050</b>	<b>9060</b>			<b>9090</b>			$+0.195$ $+0.060$	90
	<b>10050</b>		<b>10070</b>	<b>10080</b>		<b>10095</b>	<b>100100</b>	$+0.195$ $+0.060$	100
	<b>11050</b>		<b>11070</b>			<b>11095</b>	<b>110100</b>	$+0.195$ $+0.060$	110
	<b>12050</b>		<b>12070</b>			<b>12095</b>	<b>120100</b>	$+0.200$ $+0.060$	120
	<b>13050</b>			<b>13080</b>			<b>130100</b>	$+0.200$ $+0.060$	130
	<b>14050</b>			<b>14080</b>			<b>140100</b>	$+0.200$ $+0.060$	140
	<b>15050</b>			<b>15080</b>			<b>150100</b>	$+0.200$ $+0.060$	150
	<b>16050</b>			<b>16080</b>			<b>160100</b>	$+0.200$ $+0.060$	160

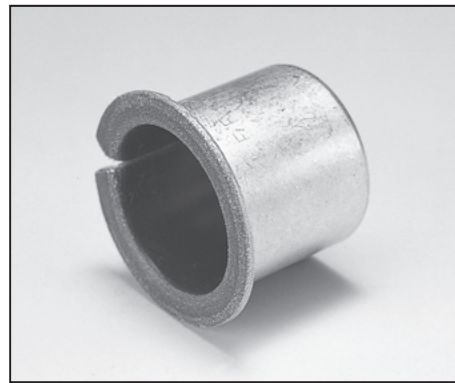

Specify Part No. by required I.D. and length.  
(e.g.) I.D. is 20mm and length is 10mm.

**LFF - 2010**  
Part No.

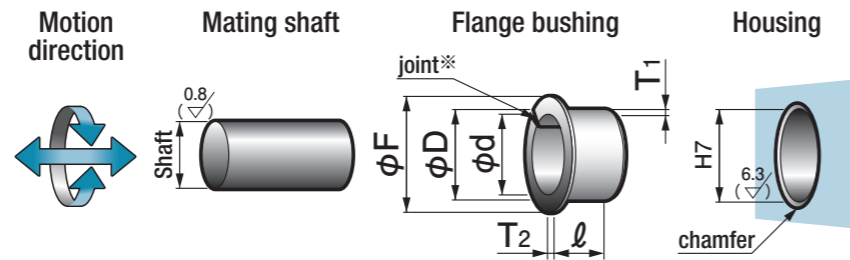

※The joint causes no influences upon rotation of the shaft. Be careful when press-fitting so that the joint is not at the position to which the maximum load is applied.

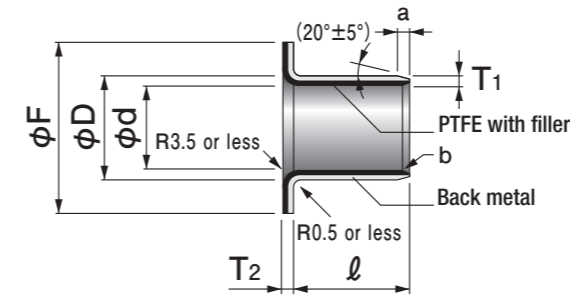

a: O.D. chamfering for the bushing I.D. of φ10 or more

T1	1.0	1.5	2.0	2.5
a	0.5	0.8	1.0	1.0

(mm)

b: I.D. chamfering for the bushing I.D. of φ10 or more

T1	1.0	1.5	2.0	2.5
b	C0.3	C0.5	C0.5	C0.5

(mm)

※ Chamfering of inner or outer diameters less than φ10 mm is done only to remove burrs.

Shaft Size	Shaft Tolerance	Housing Size	H7 Tolerance	I.D. φd	O.D. φD	φF	Flange			Wall thickness		Length ℓ Tolerance <sup>0</sup> / <sub>-0.3</sub>			
							Tolerance	T2	Tolerance	T1	Tolerance	3	4	5	6
3	-0.025/-0.034	4.6	+0.012/0	3	4.6	7	0/-0.8	0.8	0/-0.15	0.8	0/-0.025	0303		0305	
4	-0.025/-0.037	5.6	+0.012/0	4	5.6	9	0/-0.8	0.8	0/-0.15	0.8	0/-0.025		0404		0406
5	-0.025/-0.037	7	+0.015/0	5	7	10	0/-0.8	1.0	0/-0.15	1.0	0/-0.025		0504	0505	0506
6	-0.025/-0.037	8	+0.015/0	6	8	12	0/-0.8	1.0	0/-0.15	1.0	0/-0.025			0605	0606
7	-0.025/-0.040	9	+0.015/0	7	9	13	0/-0.8	1.0	0/-0.15	1.0	0/-0.025			0705	
8	-0.025/-0.040	10	+0.015/0	8	10	15	0/-0.8	1.0	0/-0.15	1.0	0/-0.025				0806
9	-0.025/-0.040	11	+0.018/0	9	11	16	0/-0.8	1.0	0/-0.15	1.0	0/-0.025				
10	-0.025/-0.040	12	+0.018/0	10	12	18	0/-0.8	1.0	0/-0.15	1.0	0/-0.025				1006
12	-0.025/-0.043	14	+0.018/0	12	14	20	0/-0.8	1.0	0/-0.15	1.0	0/-0.025				1206
13	-0.025/-0.043	15	+0.018/0	13	15	21	0/-0.8	1.0	0/-0.15	1.0	0/-0.025				
14	-0.025/-0.043	16	+0.018/0	14	16	22	0/-0.8	1.0	0/-0.15	1.0	0/-0.025				
15	-0.025/-0.043	17	+0.018/0	15	17	23	0/-0.8	1.0	0/-0.15	1.0	0/-0.025				
16	-0.025/-0.043	18	+0.018/0	16	18	24	0/-0.8	1.0	0/-0.15	1.0	0/-0.025				
18	-0.025/-0.043	20	+0.021/0	18	20	26	0/-0.8	1.0	0/-0.15	1.0	0/-0.025				
20	-0.025/-0.046	23	+0.021/0	20	23	31	0/-0.8	1.5	0/-0.15	1.5	0/-0.030				
22	-0.025/-0.046	25	+0.021/0	22	25	33	0/-0.8	1.5	0/-0.15	1.5	0/-0.030				
24	-0.025/-0.046	27	+0.021/0	24	27	35	0/-0.8	1.5	0/-0.15	1.5	0/-0.030				
25	-0.025/-0.046	28	+0.021/0	25	28	36	0/-0.8	1.5	0/-0.15	1.5	0/-0.030				
26	-0.025/-0.046	30	+0.021/0	26	30	38	0/-0.8	2.0	0/-0.15	2.0	0/-0.030				
28	-0.025/-0.046	32	+0.025/0	28	32	40	0/-0.8	2.0	0/-0.15	2.0	0/-0.030				
30	-0.025/-0.046	34	+0.025/0	30	34	42	0/-0.8	2.0	0/-0.15	2.0	0/-0.030				
31	-0.025/-0.050	35	+0.025/0	31	35	45	0/-0.8	2.0	0/-0.15	2.0	0/-0.030				
32	-0.025/-0.050	36	+0.025/0	32	36	46	0/-0.8	2.0	0/-0.15	2.0	0/-0.030				
35	-0.025/-0.050	39	+0.025/0	35	39	49	0/-0.8	2.0	0/-0.15	2.0	0/-0.030				
38	-0.025/-0.050	42	+0.025/0	38	42	52	0/-0.8	2.0	0/-0.15	2.0	0/-0.030				
40	-0.025/-0.050	44	+0.025/0	40	44	54	0/-0.8	2.0	0/-0.15	2.0	0/-0.030				
45	-0.025/-0.050	50	+0.025/0	45	50	60	0/-0.8	2.5	0/-0.15	2.5	0/-0.040				
50	-0.025/-0.050	55	+0.030/0	50	55	65	0/-0.8	2.5	0/-0.15	2.5	0/-0.040				
55	-0.025/-0.055	60	+0.030/0	55	60	70	0/-0.8	2.5	0/-0.15	2.5	0/-0.040				
60	-0.025/-0.055	65	+0.030/0	60	65	75	0/-0.8	2.5	0/-0.15	2.5	0/-0.040				

※Outer diameter is measured by exclusive gauge.  
※The I.D. tolerance after press fitting is for reference only.

7	8	10	12	15	20	25	30	40	50	60	I.D. tolerance after press fitting (reference)				
											I.D. φd	I.D. φd			
											+0.062/0	3			
											+0.062/0	4			
											+0.065/0	5			
0607	0608	0610									+0.065/0	6			
0707		0710	0712								+0.065/0	7			
	0808	0810	0812								+0.065/0	8			
		0910									+0.068/0	9			
1007	1008	1010	1012	1015							+0.068/0	10			
1207	1208	1210	1212	1215	1220						+0.068/0	12			
		1310		1315							+0.068/0	13			
		1410	1412	1415	1420						+0.068/0	14			
		1510	1512	1515	1520	1525					+0.068/0	15			
		1610	1612	1615	1620	1625					+0.068/0	16			
		1810	1812	1815	1820	1825					+0.071/0	18			
		2010	2012	2015	2020	2025	2030				+0.081/0	20			
		2210	2212	2215	2220	2225					+0.081/0	22			
				2415	2420	2425	2430				+0.081/0	24			
				2510	2512	2515	2520	2525	2530		+0.081/0	25			
						2615	2620				+0.081/0	26			
						2812	2815	2820		2830	+0.085/0	28			
						3012	3015	3020	3025	3030	3040	+0.085/0	30		
									3125			+0.085/0	31		
								3220	3225	3230		+0.085/0	32		
								3512	3520	3525	3530	3540	3550	+0.085/0	35
									3820		3830	3840		+0.085/0	38
								4012	4020	4025	4030	4040	4050	+0.085/0	40
									4520	4525	4530	4540	4550	+0.105/0	45
									5020		5030	5040		+0.110/0	50
											5530	5540		+0.110/0	55
											6030	6040		+0.110/0	60

# LFW

## Oiles Drymet LF Washers

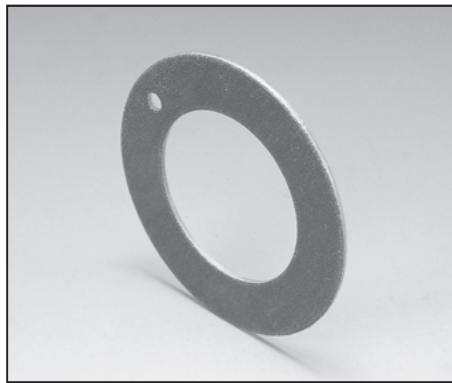

Specify Part No. by required I.D. and thickness.  
(e.g.) I.D. is 20mm and thickness is 1.5mm.

**LFW - 2015**  
Part No.

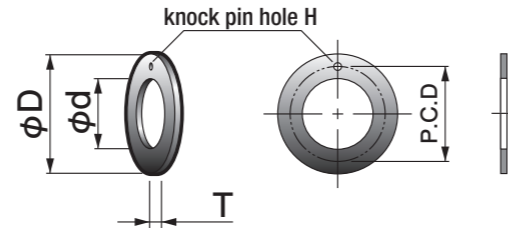

● Sliding surface consists of a plastic layer.

Part No.	I.D.		O.D.		Thickness		Knock pin hole		Position of knock pin	
	φd	Tolerance	φD	Tolerance	T	Tolerance	H	Tolerance	P.C.D.	Tolerance
LFW-0815	8	+0.25 0	16	0 -0.25	1.5	-0.03 -0.08	1	+0.30 +0.10	12	±0.12
LFW-1015	10	+0.25 0	18	0 -0.25	1.5	-0.03 -0.08	1	+0.30 +0.10	14	±0.12
LFW-1215	12	+0.25 0	24	0 -0.25	1.5	-0.03 -0.08	1.5	+0.375 +0.125	18	±0.12
LFW-1415	14	+0.25 0	26	0 -0.25	1.5	-0.03 -0.08	2	+0.375 +0.125	20	±0.12
LFW-1615	16	+0.25 0	30	0 -0.25	1.5	-0.03 -0.08	2	+0.375 +0.125	23	±0.12
LFW-1815	18	+0.25 0	32	0 -0.25	1.5	-0.03 -0.08	2	+0.375 +0.125	25	±0.12
LFW-2015	20	+0.25 0	36	0 -0.25	1.5	-0.03 -0.08	3	+0.375 +0.125	28	±0.12
LFW-2215	22	+0.25 0	38	0 -0.25	1.5	-0.03 -0.08	3	+0.375 +0.125	30	±0.12
LFW-2415	24	+0.25 0	42	0 -0.25	1.5	-0.03 -0.08	3	+0.375 +0.125	33	±0.12
LFW-2615	26	+0.25 0	44	0 -0.25	1.5	-0.03 -0.08	3	+0.375 +0.125	35	±0.12
LFW-2815	28	+0.25 0	48	0 -0.25	1.5	-0.03 -0.08	4	+0.375 +0.125	38	±0.12
LFW-3215	32	+0.25 0	54	0 -0.25	1.5	-0.03 -0.08	4	+0.375 +0.125	43	±0.12
LFW-3815	38	+0.25 0	62	0 -0.25	1.5	-0.03 -0.08	4	+0.375 +0.125	50	±0.12
LFW-4215	42	+0.25 0	66	0 -0.25	1.5	-0.03 -0.08	4	+0.375 +0.125	54	±0.12
LFW-4820	48	+0.25 0	74	0 -0.25	2.0	-0.03 -0.08	4	+0.375 +0.125	61	±0.12
LFW-5220	52	+0.25 0	78	0 -0.25	2.0	-0.03 -0.08	4	+0.375 +0.125	65	±0.12

# LFCF

## Oiles Drymet LF (t0.5)

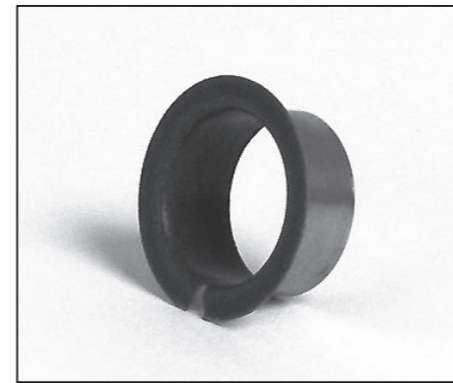

Specify Part No. by required I.D. and length.  
(e.g.) I.D. is 8mm and length is 5.5mm.

**LFCF - 0805**  
Part No.

### Feature

- This bearing is as thin as 0.5 mm, allowing the user who gives up an idea to use a bearing in a small space to use it.
- The sliding layer made of plastic containing special additives maintains stable coefficient of friction. It is effective to reduce abnormal noise and wear in applications without bushings.

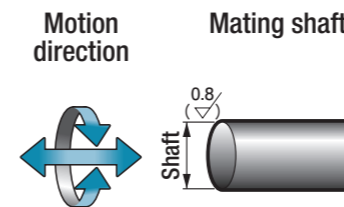

Tolerance of mating shaft  
General use, high load e7

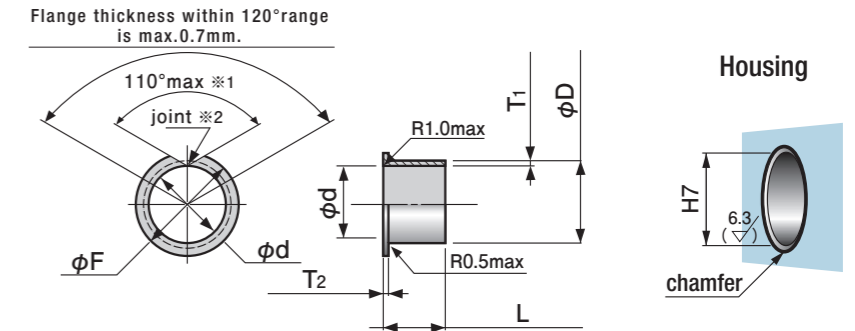

- ※1 The degree shown is after press-fitted into the ring gauge of φD +0.055mm. (the ring gauge of φD +0.060mm is used for the bushings of φ11 or bigger.)
- ※2 The joint causes no influences upon rotation of the shaft. Be careful when press-fitting so that the joint is not at the position to which the maximum load is applied.
- ※3 There is no chamfer on LFCF.

Part No.	I.D.		O.D.		Flange			Thick bushing		Length L Tolerance ±0.3	I.D. tolerance after press fitting (reference)	
	φd	Tolerance	φD	Tolerance	φF	Tolerance	T <sub>2</sub>	Tolerance	T <sub>1</sub>			Tolerance
LFCF-0505	5		6	+0.055 +0.025	8.5	±0.5	0.48	±0.05	0.48	±0.02	5.5	+0.092 0
LFCF-0605	6		7	+0.055 +0.025	10	±0.5	0.48	±0.05	0.48	±0.02	5.5	+0.095 0
LFCF-0705	7		8	+0.055 +0.025	11	±0.5	0.48	±0.05	0.48	±0.02	5.5	+0.095 0
LFCF-0805	8		9	+0.055 +0.025	12	±0.5	0.48	±0.05	0.48	±0.02	5.5	+0.095 0
LFCF-1006	10		11	+0.060 +0.030	15	±0.5	0.48	±0.05	0.48	±0.02	6.5	+0.098 0
LFCF-1206	12		13	+0.060 +0.030	17	±0.5	0.48	±0.05	0.48	±0.02	6.5	+0.098 0
LFCF-1606	16		17	+0.060 +0.030	21	±0.5	0.48	±0.05	0.48	±0.02	6.5	+0.098 0

- ※Outer diameter is measured by exclusive gauge.
- ※I.D. after press-fitted into the housing of φD H7 is reference value.

# LFP Oiles Drymet LF Plates

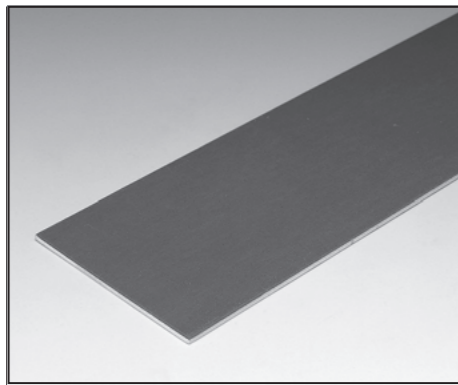

Specify Part No. by required thickness and width.  
(e.g.) Thickness is 1.5mm and width is 90mm.

**LFP - 1590**  
Part No.

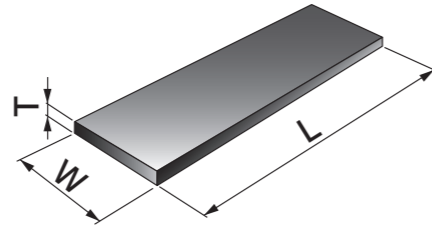

● Sliding surface consists of a plastic layer.

Part No.	Thickness		Width	Length
	T	Tolerance	W	L
<b>LFP-1080</b>	1.0	-0.03 -0.13	80	500
<b>LFP-1590</b>	1.5	-0.03 -0.13	90	500
<b>LFP-20100</b>	2.0	-0.03 -0.13	100	500
<b>LFP-25100</b>	2.5	-0.03 -0.13	100	500

# Oiles LF Guides Guide unit bearings



Standard product



## Feature

- Incorporates Oiles bearings for self-lubricating operations.
- Features low coefficient of friction and superior wear resistance.
- Easily mountable. Compatible with ball bearing types.
- Low prices with simple structures.

## Design condition

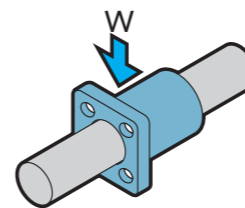

Part No.	Allowable load W N [kgf]		Allowable velocity m/s [m/min]	Service temperature range °C
	Dynamic	Static		
<b>LFG12-30</b>	235 { 24}	706 { 72}	0.67 {40}	-30~+130*
<b>LFG16-37</b>	376 { 38}	1,129 {115}		
<b>LFG20-42</b>	588 { 60}	1,764 {180}		
<b>LFG25-59</b>	980 {100}	2,940 {300}		
<b>LFG30-64</b>	1,323 {135}	3,969 {405}		

\*Temperature range for dust seal.

\*Unusable under the condition of water, splashing water and high humidity.

## How to attach washers, plates

### ① Knock pin method (Thrust washer)

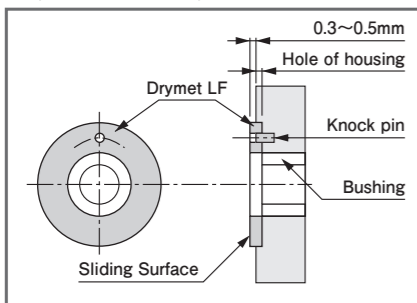

\*Sliding surface consists of a plastic layer.

### ② Inlay method (Plate)

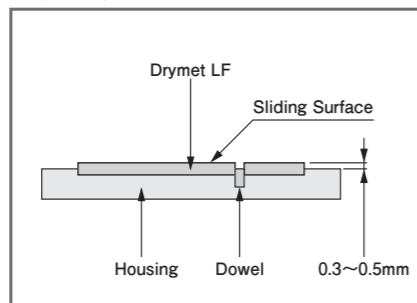

\*Sliding surface consists of a plastic layer.

### ③ Flat head screw method

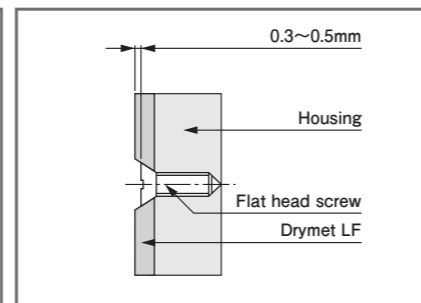

### ④ Using glue

In the case of (2), the washer and plate may be inserted with glue, not a knock pin. Synthetic epoxy plastic glue is suitable, though no glue is specified, in particular. Be careful because fitting with glue only may result in separation in some cases.