



材質  
 OILES#2000 (焼結合金+スチール)  
 Material  
 OILES#2000 (Sintered Alloy + Steel)

ご注文方法  
**ORDERING METHOD**

**CUP - 34150**  
 Parts No.

例:幅34mm、長さ150mmの場合  
 EX:W34mm×L150mm



材質  
 OILES#2000 (焼結合金+スチール)  
 Material  
 OILES#2000 (Sintered Alloy + Steel)

ご注文方法  
**ORDERING METHOD**

**CCS - 25150**  
 Parts No.

例:厚み25mm、長さ150mmの場合  
 EX:T25mm×L150mm

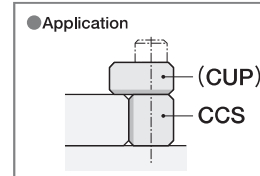
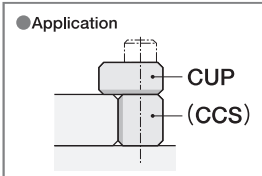
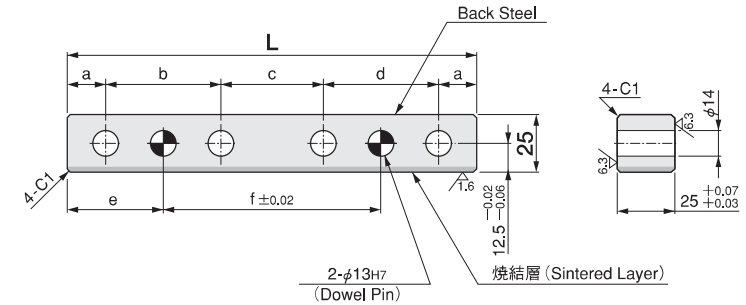
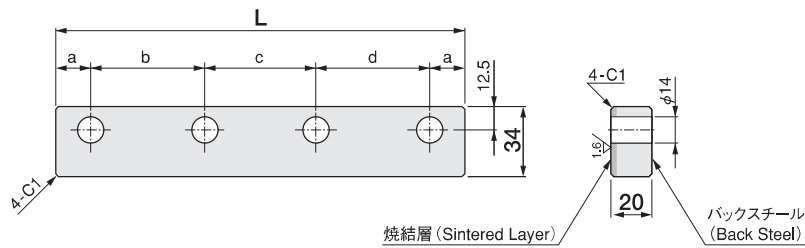

Parts No.	L	a	b	c	d	Holes	適合サイドブロック規格 Matching Side Block
<b>CUP-34100</b>	100	15	70	—	—	2	CCS-25100
<b>CUP-34150</b>	150	—	55	55	—	3	CCS-25150
<b>CUP-34200</b>	200	20	50	50	55	4	CCS-25200
<b>CUP-34250</b>	250	—	70	70	70	4	CCS-25250

CAD

Parts No.	L	a	b	c	d	Holes	e	f	適合アップパープレート規格 Matching Upper Plate
<b>CCS-25100</b>	100	15	70	—	—	2	35	30	CUP-34100
<b>CCS-25150</b>	150	—	55	55	—	3	—	50	CUP-34150
<b>CCS-25200</b>	200	20	50	50	55	4	50	100	CUP-34200
<b>CCS-25250</b>	250	—	70	70	70	4	—	150	CUP-34250

CAD