

Oiles Glitron S/SE Polyphenylene sulfide bearings with fillers



Feature

- Serviceable completely without the need for lubrication.
- Features small difference between the static and dynamic coefficient of frictions and offers stable friction characteristics free from stick slips.
- Features low coefficient of friction and superior wear resistance.
- Applicable to wide temperature ranges from low to high temperatures.
- Has superior chemical resistance.
- Soft metal (such as aluminum) may be used as mating shafts.
- Injection-molded and has good mass productivity. Features superior dimensional stability, allowing high-precision designs.
- Has antistatic-level conductivity. [Glitron SE]
- The standard products in various sizes applicable to miniature bearings are available. [Glitron SE]

Service range

Lubrication condition	Dry
Service temperature range °C	-60~+200
Allowable max. pressure P N/mm ² {kgf/cm ² }	14.5 {148}
Allowable max. velocity V m/s {m/min}	2.50 {150}
Allowable max. PV value N/mm ² · m/s {kgf/cm ² · m/min}	0.65 {398}

Mechanical properties			Glitron S	Glitron SE
Specific gravity	ASTM D 792	—	1.6	1.6
Tensile strength	ASTM D 638	N/mm ² {kgf/cm ² }	53.9 {550}	41.3 {421.1}
Tensile elongation at break	ASTM D 638	%	2.50	0.99
Flexural property	ASTM D 790	N/mm ² {kgf/cm ² }	83.3 {850}	62.9 {641.6}
Flexural modulus	ASTM D 790	N/mm ² {kgf/cm ² }	3,430 {35,000}	3,430 {35,000}
Compressive stress 5% deformation	ASTM D 695	N/mm ² {kgf/cm ² }	68.6 {700}	72.4 {739}
Hardness	ASTM D 785	HRR	110	116
Izod impact strength (with notch)	ASTM D 256	J/m {kgfcm/cm}	14.7 {1.50}	15.2 {1.55}
Co-efficient of linear expansion	ASTM D 696	×10 ⁻⁵ °C ⁻¹	7	7
Deflection temperature under load 1.82 MPa	ASTM D 648	°C	150	167
Melting point	DSC	°C	281	281
Volume resistivity	ASTM D 257	Ωm {Ω · cm}	—	2.4×10 ² {2.4×10 ⁴ }
Surface resistivity	ASTM D 257	Ω	—	1.67×10 ⁵
UL incombustibility	UL94	File No.E78113	V-0	V-0

※The values shown above are typical values, not the standard values.

Oiles Glitron S/SE Polyphenylene sulfide bearings with fillers

Test data

Journal rotation test

<Testing conditions>
 Bearing dimension : $\phi 10 \times \phi 14 \times l 10$
 Mating material : SUS440 (surface roughness $Ra 0.2 \mu m$)
 Pressure : $0.245 N/mm^2$ { $2.5 kgf/cm^2$ }
 Velocity : $1.049 m/s$ (2,000rpm) { $62.8 m/min$ }
 Test time : 60h
 Lubrication : dry

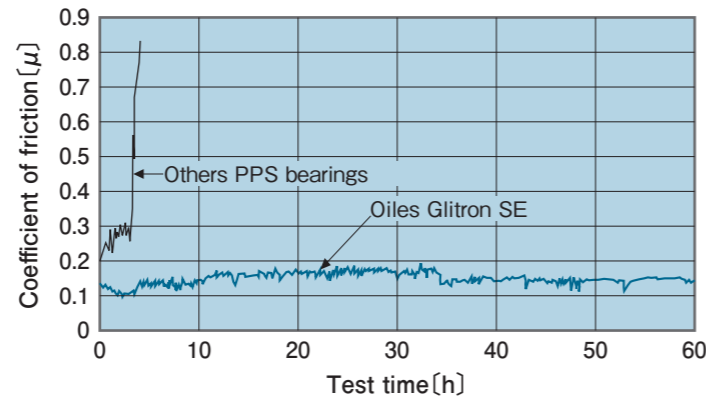
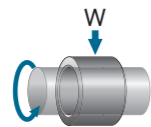

Thrust test

<Testing conditions>
 Mating material : SUS303
 (surface roughness $Rz 1.2 \mu m$)
 Velocity : $0.167 m/s$ { $10.0 m/min$ }
 Lubrication : dry

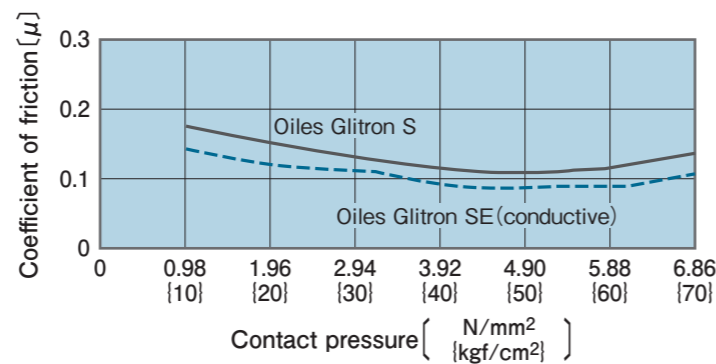
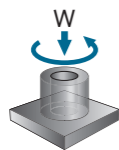

Journal rotation test

<Testing conditions>
 Mating material : SUS303
 (surface roughness $Rz 1.2 \mu m$)
 Pressure : $0.98 N/mm^2$ { $10.0 kgf/cm^2$ }
 Velocity : $0.333 m/s$ { $20.0 m/min$ }
 Test time : 20h
 Lubrication : dry

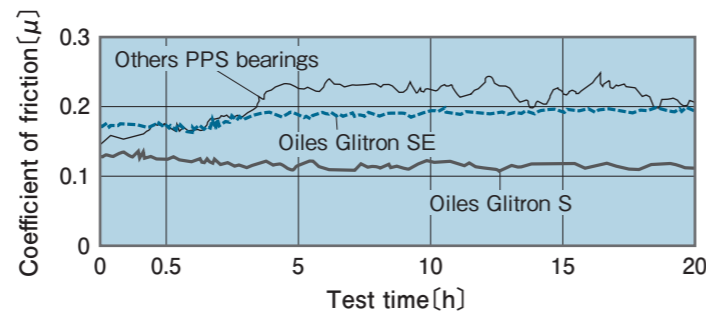
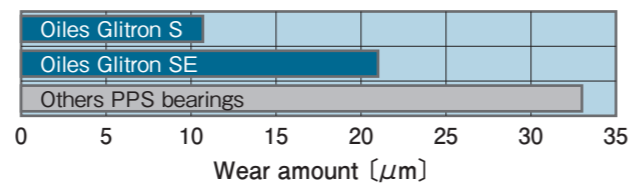
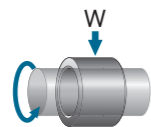

Test data

High temperature journal rotation test

<Testing conditions>
 Mating material : aluminium (A5056)
 Pressure : $0.98 N/mm^2$ { $10.0 kgf/cm^2$ }
 Velocity : $0.06 m/s$ { $3.6 m/min$ }
 Atmospheric temperature : $160^\circ C$
 Test time : 100h
 Lubrication : dry

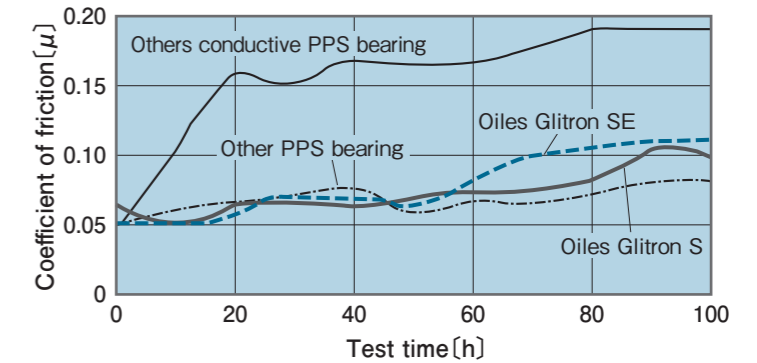
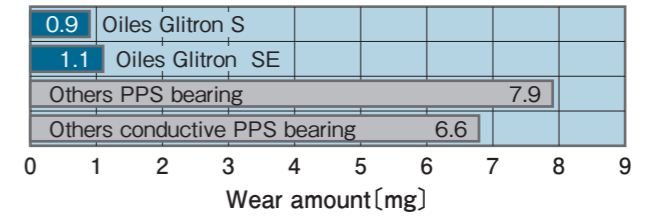
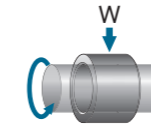

High velocity journal bearing rotation test

<Testing conditions>
 Mating material : SUS303
 (surface roughness $Rz 2.5 \mu m$)
 Pressure : $0.49 N/mm^2$ { $5.0 kgf/cm^2$ }
 Velocity : $0.67 m/s$ { $40.0 m/min$ }
 Test time : 100h
 Lubrication : dry

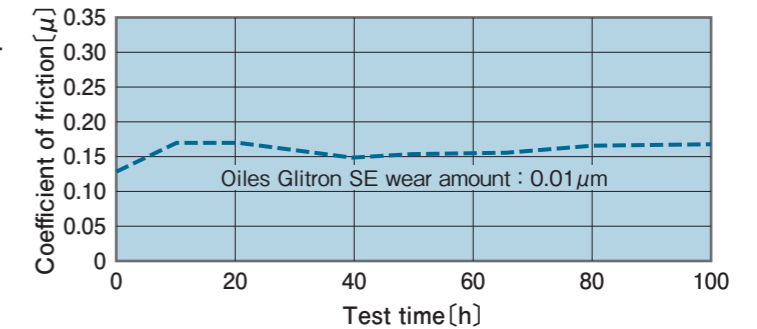
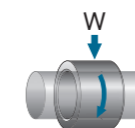

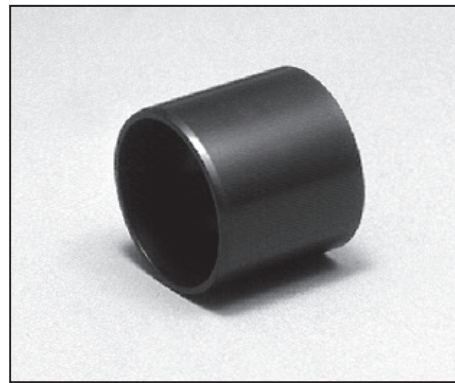

Specify Part No. by required I.D., O.D. and Length.
(e.g.) I.D. is 10mm, O.D. is 14mm, and length is 10mm.

GEB - 1010
Part No.

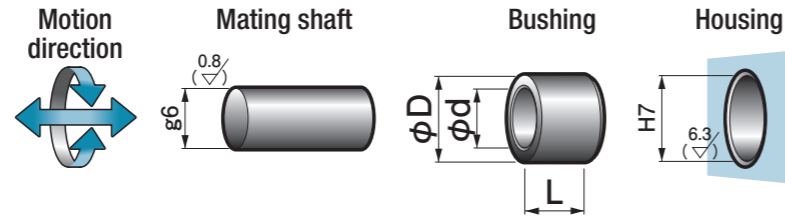

Type A

Type B

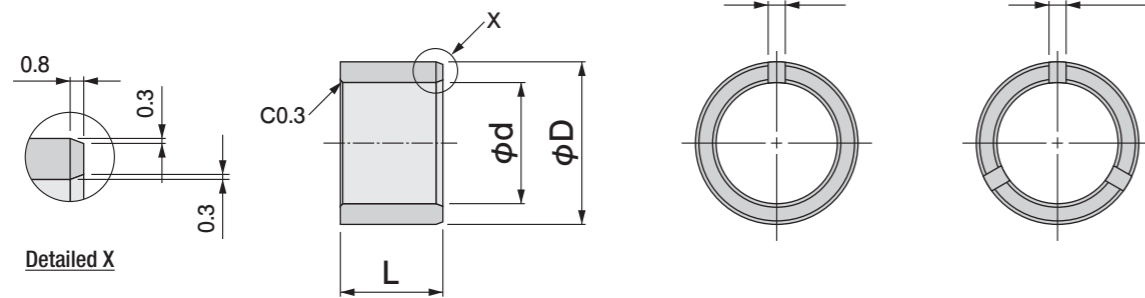

Part No.	I.D.*		O.D.		Length		Type
	φd	Tolerance	φD	Tolerance	L	Tolerance	
GEB-0305	3	+0.070 +0.040	6	+0.052 +0.012	5	0 -0.10	A
GEB-0405	4	+0.070 +0.040	7	+0.055 +0.015	5	0 -0.10	A
GEB-0505	5	+0.070 +0.040	8	+0.055 +0.015	5	0 -0.10	A
GEB-0605	6	+0.070 +0.040	9	+0.055 +0.015	5	0 -0.10	A
GEB-0808	8	+0.075 +0.040	12	+0.068 +0.018	8	0 -0.10	A
GEB-1010	10	+0.095 +0.060	14	+0.068 +0.018	10	0 -0.10	A
GEB-1210	12	+0.100 +0.060	16	+0.068 +0.018	10	0 -0.10	A
GEB-1515	15	+0.100 +0.060	19	+0.068 +0.018	15	0 -0.15	B
GEB-1615	16	+0.100 +0.060	20	+0.071 +0.021	15	0 -0.15	B
GEB-2020	20	+0.110 +0.060	25	+0.081 +0.021	20	0 -0.15	B
GEB-2525	25	+0.110 +0.060	30	+0.081 +0.021	25	0 -0.15	B
GEB-3030	30	+0.130 +0.060	35	+0.095 +0.025	30	0 -0.20	B

*The inner diameter tolerances are the values after pressing into a ring gauge of φD ±0.002.

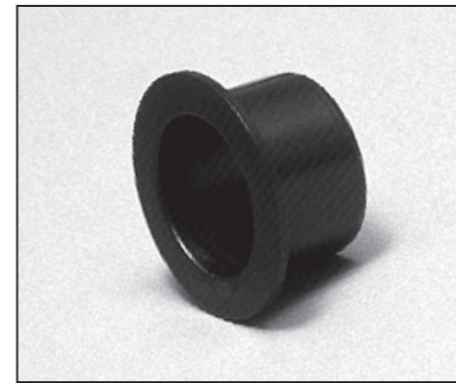

Specify Part No. by required I.D., O.D. and Length.
(e.g.) I.D. is 10mm, O.D. is 14mm, and length is 8mm.

GEF - 1008
Part No.

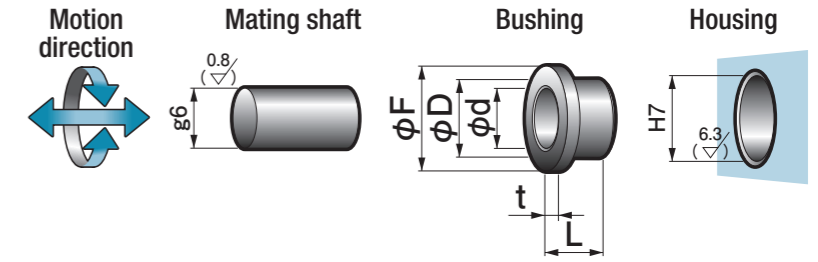

Type A

Type B

Type C

Type D

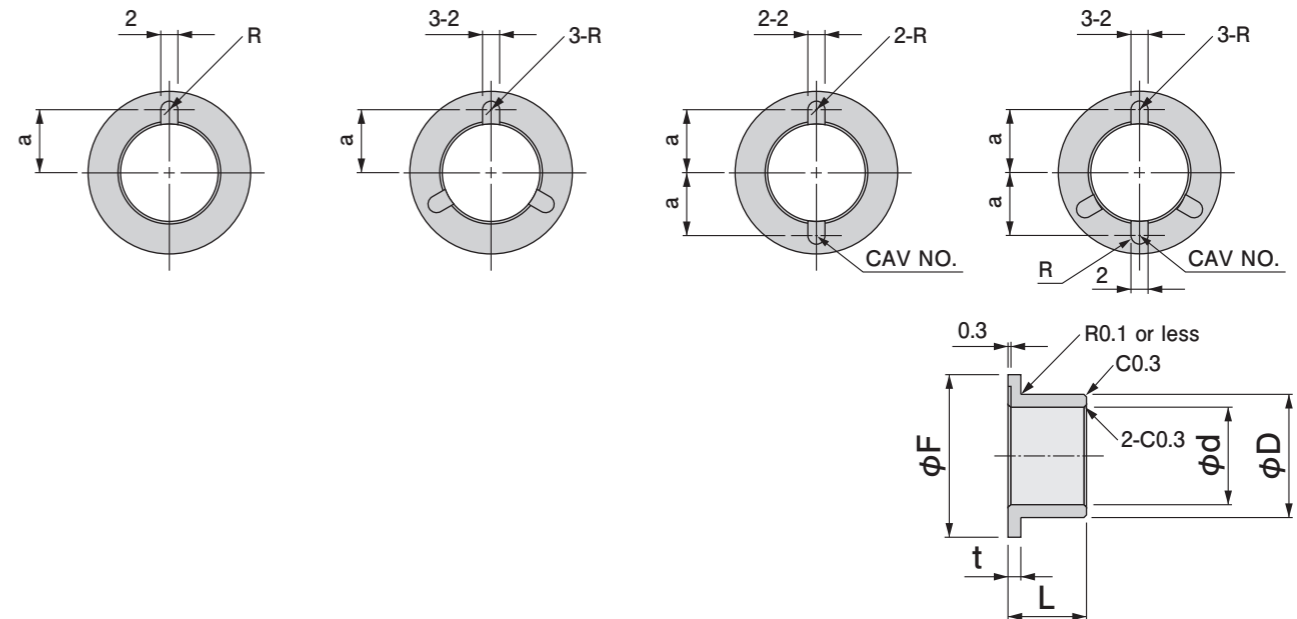

Part No.	I.D.*		O.D.		Length		Flange			Type	a	
	φd	Tolerance	φD	Tolerance	L	Tolerance	φF	Tolerance	t			Tolerance
GEF-0304	3	+0.070 +0.040	6	+0.052 +0.012	4	0 -0.10	9	0 -0.10	1.5	0 -0.10	A	3.0
GEF-0404	4	+0.070 +0.040	7	+0.055 +0.015	4	0 -0.10	10	0 -0.10	1.5	0 -0.10	A	3.5
GEF-0505	5	+0.070 +0.040	8	+0.055 +0.015	5	0 -0.10	11	0 -0.10	1.5	0 -0.10	A	4.0
GEF-0605	6	+0.070 +0.040	9	+0.055 +0.015	5	0 -0.10	12	0 -0.10	1.5	0 -0.10	C	4.5
GEF-0806	8	+0.075 +0.040	12	+0.068 +0.018	6	0 -0.10	16	0 -0.10	2.0	0 -0.10	A	5.5
GEF-1008	10	+0.095 +0.060	14	+0.068 +0.018	8	0 -0.10	18	0 -0.10	2.0	0 -0.10	C	6.5
GEF-1208	12	+0.100 +0.060	16	+0.068 +0.018	8	0 -0.10	20	0 -0.10	2.0	0 -0.10	D	7.5
GEF-1510	15	+0.100 +0.060	19	+0.068 +0.018	10	0 -0.10	23	0 -0.10	2.0	0 -0.10	B	9.0
GEF-1610	16	+0.100 +0.060	20	+0.071 +0.021	10	0 -0.10	24	0 -0.10	2.0	0 -0.10	B	9.5
GEF-2012	20	+0.110 +0.060	25	+0.081 +0.021	12	0 -0.15	30	0 -0.15	2.5	0 -0.15	B	11.5
GEF-2515	25	+0.110 +0.060	30	+0.081 +0.021	15	0 -0.15	35	0 -0.20	2.5	0 -0.15	B	14.0
GEF-3020	30	+0.130 +0.060	35	+0.095 +0.025	20	0 -0.20	40	0 -0.20	2.5	0 -0.15	B	16.5

*The inner diameter tolerances are the values after pressing into a ring gauge of φD ±0.002.

GSB Oiles Glitron SE Bushings

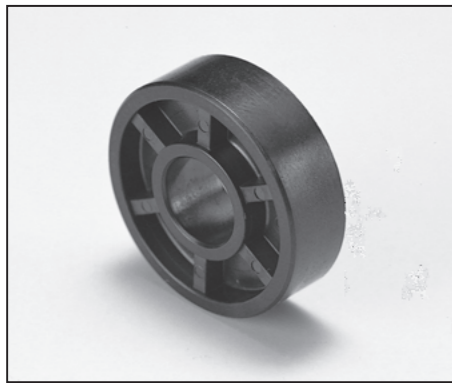

Specify Part No. by required I.D., O.D. and Length.
(e.g.) I.D. is 5mm, O.D. is 10mm, and length is 4mm.

GSB - 051004
Part No.

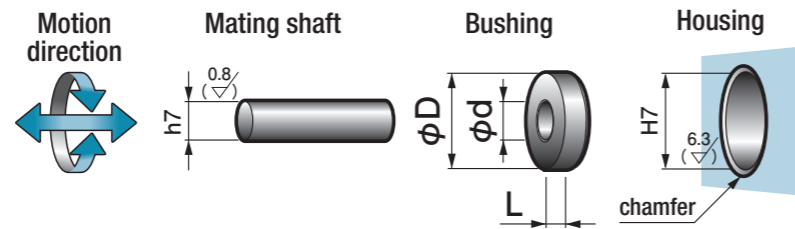

Products compatible with miniature bearings.

Type A

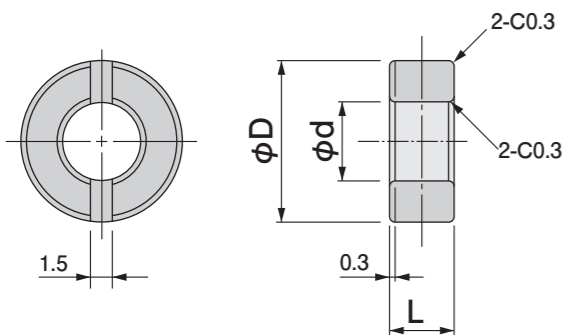

Type B

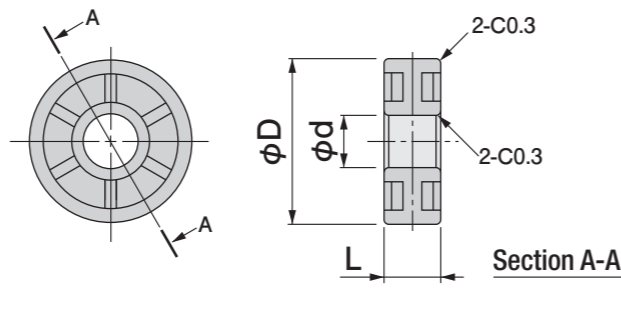

Part No.	I.D.		O.D.		Length		Allowable revolution S ⁻¹ (rpm)	Allowable load N [kgf]	Type	Ball bearing part code
	phi d	Tolerance	phi D	Tolerance	L	Tolerance				
GSB-031004	3	+0.09 +0.04	10	+0.05 0	4	0 -0.1	71.67 {4,300}	12 {1.2}	A	623
GSB-040803	4	+0.09 +0.04	8	+0.05 0	3	0 -0.1	53.33 {3,200}	12 {1.2}	A	—
GSB-041004	4	+0.09 +0.04	10	+0.05 0	4	0 -0.1	53.33 {3,200}	16 {1.6}	A	—
GSB-041104	4	+0.09 +0.04	11	+0.05 0	4	0 -0.1	53.33 {3,200}	16 {1.6}	A	694
GSB-041204	4	+0.09 +0.04	12	+0.05 0	4	0 -0.1	53.33 {3,200}	16 {1.6}	B	604
GSB-051004	5	+0.09 +0.04	10	+0.05 0	4	0 -0.1	41.67 {2,500}	20 {2.0}	A	—
GSB-051105	5	+0.09 +0.04	11	+0.05 0	5	0 -0.1	41.67 {2,500}	25 {2.6}	A	685
GSB-051405	5	+0.09 +0.04	14	+0.05 0	5	0 -0.1	41.67 {2,500}	25 {2.6}	B	605
GSB-051605	5	+0.09 +0.04	16	+0.05 0	5	0 -0.1	41.67 {2,500}	25 {2.6}	B	625
GSB-061003	6	+0.09 +0.04	10	+0.05 0	3	0 -0.1	35.00 {2,100}	18 {1.8}	A	676
GSB-061204	6	+0.09 +0.04	12	+0.05 0	4	0 -0.1	35.00 {2,100}	24 {2.4}	A	—
GSB-061305	6	+0.09 +0.04	13	+0.05 0	5	0 -0.1	35.00 {2,100}	29 {3.0}	A	686
GSB-061505	6	+0.09 +0.04	15	+0.05 0	5	0 -0.1	35.00 {2,100}	29 {3.0}	B	696
GSB-081235	8	+0.09 +0.04	12	+0.05 0	3.5	0 -0.1	26.67 {1,600}	27 {2.8}	A	678
GSB-081404	8	+0.09 +0.04	14	+0.05 0	4	0 -0.1	26.67 {1,600}	31 {3.2}	A	—
GSB-081605	8	+0.09 +0.04	16	+0.05 0	5	0 -0.1	26.67 {1,600}	39 {4.0}	B	—
GSB-082207	8	+0.09 +0.04	22	+0.05 0	7	0 -0.1	26.67 {1,600}	55 {5.6}	B	608

GSF Oiles Glitron SE Flange Bushings

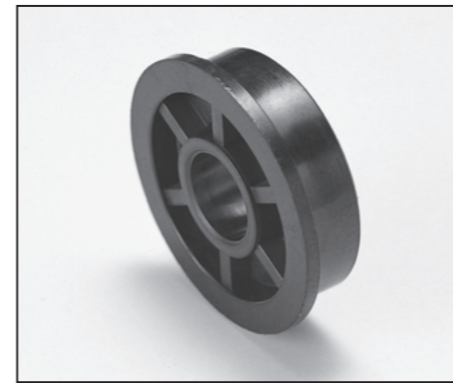

Specify Part No. by required I.D., O.D. and Length.
(e.g.) I.D. is 5mm, O.D. is 10mm, and length is 4mm.

GSF - 051004
Part No.

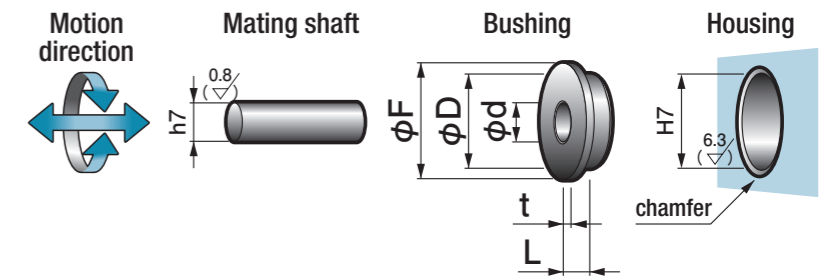

Products compatible with miniature bearings.

Type A

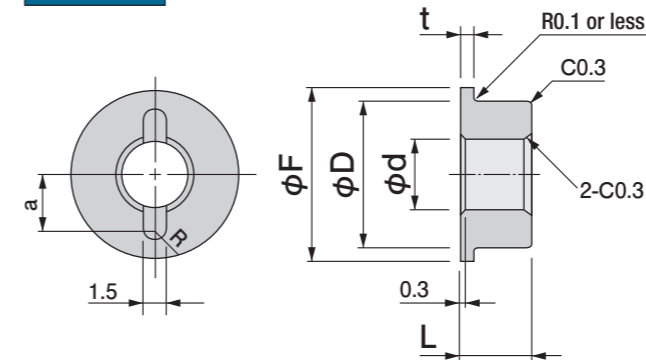

Type B

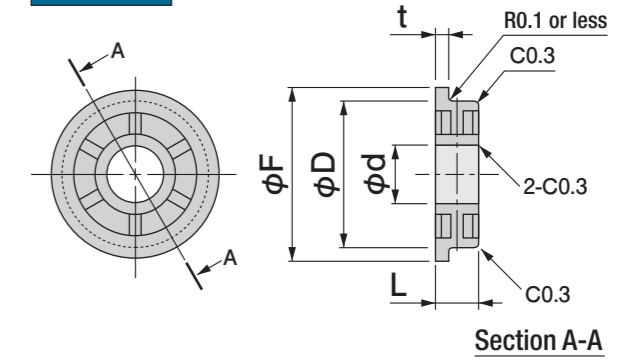

Part No.	I.D.		O.D.		Length		Flange			a	Allowable revolution S ⁻¹ (rpm)	Allowable load N [kgf]	Type	Ball bearing part code
	phi d	Tolerance	phi D	Tolerance	L	Tolerance	phi F	t	Tolerance t					
GSF-040803	4	+0.09 +0.04	8	+0.05 0	3	0 -0.1	9.2	0.6	0 -0.1	2.8	53.33 {3,200}	12 {1.2}	A	—
GSF-040904	4	+0.09 +0.04	9	+0.05 0	4	0 -0.1	10.3	1.0	0 -0.1	3.0	53.33 {3,200}	16 {1.6}	A	684
GSF-041104	4	+0.09 +0.04	11	+0.05 0	4	0 -0.1	12.5	1.0	0 -0.1	—	53.33 {3,200}	16 {1.6}	A	694
GSF-041204	4	+0.09 +0.04	12	+0.05 0	4	0 -0.1	13.5	1.0	0 -0.1	—	53.33 {3,200}	16 {1.6}	B	604
GSF-051004	5	+0.09 +0.04	10	+0.05 0	4	0 -0.1	11.6	0.8	0 -0.1	3.5	41.67 {2,500}	20 {2.0}	A	—
GSF-051105	5	+0.09 +0.04	11	+0.05 0	5	0 -0.1	12.5	1.0	0 -0.1	4.0	41.67 {2,500}	25 {2.6}	A	685
GSF-051304	5	+0.09 +0.04	13	+0.05 0	4	0 -0.1	15.0	1.0	0 -0.1	—	41.67 {2,500}	20 {2.0}	B	695
GSF-061003	6	+0.09 +0.04	10	+0.05 0	3	0 -0.1	11.2	0.6	0 -0.1	3.8	35.00 {2,100}	18 {1.8}	A	—
GSF-061204	6	+0.09 +0.04	12	+0.05 0	4	0 -0.1	13.6	0.8	0 -0.1	4.6	35.00 {2,100}	24 {2.4}	A	—
GSF-061305	6	+0.09 +0.04	13	+0.05 0	5	0 -0.1	15.0	1.1	0 -0.1	—	35.00 {2,100}	29 {3.0}	A	686
GSF-061505	6	+0.09 +0.04	15	+0.05 0	5	0 -0.1	17.0	1.2	0 -0.1	—	35.00 {2,100}	29 {3.0}	B	696
GSF-081235	8	+0.09 +0.04	12	+0.05 0	3.5	0 -0.1	13.6	0.8	0 -0.1	5.0	26.67 {1,600}	27 {2.8}	A	678
GSF-081404	8	+0.09 +0.04	14	+0.05 0	4	0 -0.1	15.6	0.8	0 -0.1	5.6	26.67 {1,600}	31 {3.2}	A	—
GSF-081605	8	+0.09 +0.04	16	+0.05 0	5	0 -0.1	18.0	1.0	0 -0.1	—	26.67 {1,600}	39 {4.0}	B	688
GSF-082207	8	+0.09 +0.04	22	+0.05 0	7	0 -0.1	25.0	1.5	0 -0.1	—	26.67 {1,600}	55 {5.6}	B	608